

Operations Manual

DPR2000 - Single Pass Dough Sheeter

Model #: DPR2000



PROLUXE
WWW.PROLUXE.COM

Version: 72125

Congratulations on your selection of the Single Pass Dough Sheeter is a leading manufacturer of food preparation and cooking equipment designed for the most demanding commercial kitchens. Proluxe equipment is a result of the highest quality engineering and time-tested design.

This manual includes installation, operation, and maintenance procedures for your new dough sheeter. Please read this manual carefully and keep it with your machine for proper operation and lasting service.

Electrical:
208V/50-60Hz/2800W/13.5 Amps
1 phase

Also available; specify when ordering:

- Voltage: 208
- Amps: 13.5/14.2
- Watts: 2800

Includes: 72" cord and 6-30P NEMA approved plug.

Shipping Weight:
88lbs. (39kg)

INTERNATIONAL SYMBOLS

Symboles internationaux



Power Off
éteindre



Power On
allumer



Hot Surface
surface chaude



Risk of Electrical Shock
Risque de choc électrique



Protective Earth Terminal
Borne de terre de protection



Caution - Warning
chaud - avertissement

SAFETY SUMMARY



Warning

To reduce the risk of electrical shock, do not remove or open cover. No user-serviceable parts inside. Refer servicing to qualified personnel.

Avertissement

Pour réduire le risque de choc électrique, ne pas retirer ou couvercle ouvert Aucune pièce réparable par l'utilisateur, reportez-vous à du personnel qualifié.



Warning

In case of power cord damage, do not attempt to repair or replace the power cord. Please contact the manufacturer or the local distributor.

Avertissement

Pour une protection continue contre l'incendie et de choc électrique, remplacer avec le même type et calibre du fusible. Mis fusible supplémentaire nominale max 3A, 120 Vac.



Warning

For continued protection against fire and electric shock, replace with the same type and rating fuse. Listed Supplemental Fuse rated max 3A, 120Vac.

Avertissement

Pour une protection continue contre l'incendie et de choc électrique, remplacer avec le même type et calibre du fusible. Mis fusible supplémentaire nominale max 3A, 120 Vac.



Caution Hot

Avoid touching hot surfaces while operating the machine.

Attention à chaud

Évitez de toucher les surfaces chaudes lorsque vous utilisez la machine.



Caution

When servicing or cleaning the machine, make sure that the power cord is removed from the wall socket.

During normal operation, the base of the machine must be installed or placed above the wall socket.

Avertissement

Lors de l'entretien ou du nettoyage de la machine, assurez-vous que le cordon d'alimentation est débranché de la prise murale.

GETTING STARTED

Please read carefully before attempting to use this appliance. DO NOT touch hot surfaces.

1. Carefully unpack and clean platen with mild soap and wipe clean with water.
2. Place in a location where it will be used allowing for clearances per the dimensions.
3. Plug into proper 208V wall outlet. If other appliances are connected to the same circuit make sure the total load does not exceed maximum ampacity of the circuit.

HOW TO OPERATE

Guidelines for operating your new dough roller safely:

1. Turn on the unit by pressing the green power button.
2. Adjust the thickness of the rollers by rotating the easy adjust arm on the right side of the unit.
3. Pre flour the hopper to make sure the rollers have been coated. Apply a liberal amount of flour to your pre-portioned dough ball.
4. Slide your dough ball through the hopper, and catch it on the other end. You may have to run your dough ball through multiple times to achieve your desired thickness.

HOW TO CLEAN

Proluxe machines are relatively maintenance-free. For a long lifespan, please follow the following care procedures.

1. Unplug the unit before cleaning.
2. Loosen the 2 housing screws on the front panel of the machine. Then lift up the front panel.
3. Start by removing the two springs off of the lower scraper.
4. Detach springs at each end.
5. Remove all scrapers.
6. Clean rollers, scrapers, tray, and machine housing with mild soap and wipe clean with a damp cloth.
7. Re-attach the scrapers and springs.
8. Lower the front panel and tighten the two housing screws.

Service Problems

Contact our factory at (800) 624-6717 (U.S. only) or approved service agency. When contacting the factory for information, parts or service instructions, please provide the serial number of the machine be provided. This number can be found on the serial plate located on the rear of the machine.

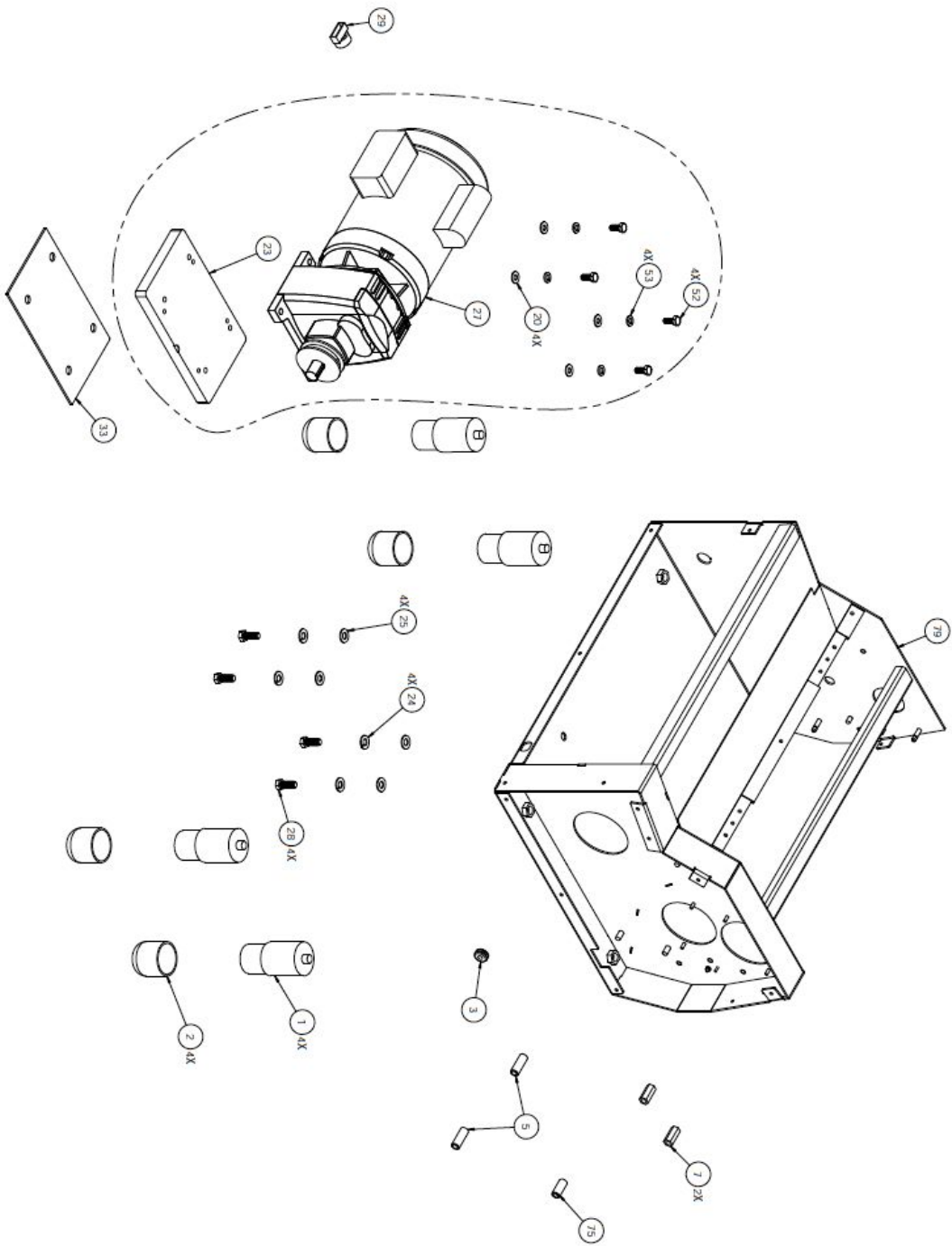

EXPDPR2000 RD 011819
 CEIEC MANUAL SHEET 1 OF 3

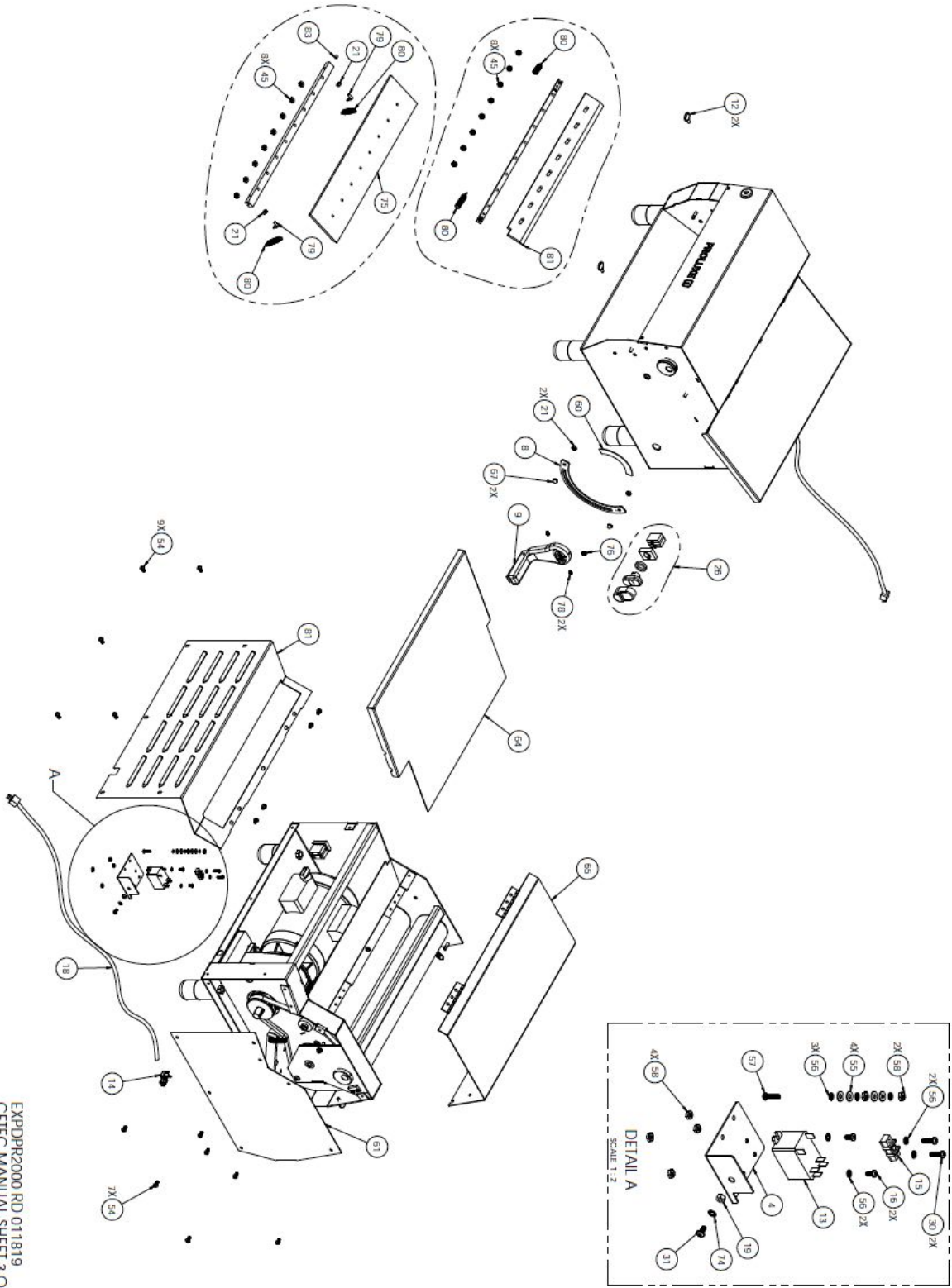

EXPDP2000 RD 011819
 CEFC MANUAL SHEET 3 OF 3

Part List - Model #: DPR2000

ITEM #	DESCRIPTION	DPR2000A	DPR2000B	QTY.
1	APPLIANCE LEGS 4" STAINLESS STEEL	1101097091	1101097091	4
2	RUBBER FOOT	1101097096	1101097096	4
3	GROMMET, RUBBER 3/8 ID, 7/8" OD, 3/16 THIK	110969116	110969116	1
4	BRACKET, RELAY	1101097080	1101097080	1
5	THREADED SPACER	1101097074	1101097074	2
6	BELT GUARD	11059052	11059052	1
7	NUT COUPLING 5/16-18 X 1-1/8	1101097094	1101097094	2
8	ADJUSMENT PLATE	1101097119	1101097119	1
9	HANDLE ADJUSMENT ASSEMBLY	1101097118	1101097118	1
10	PROXIMITY SWITCH SENSOR	1101097082	1101097082	2
11	MIDDLE ROLLER SPACER	1101097105	1101097105	2
12	THUMB SCREW WITH SHOULDER	1101097086	1101097086	2
13	RELAY, TERMS 30A 250V	1101097081	1101097081	1
14	STRAIN RELIEF	MPS90014	MPS90014	1
15	TERMINAL BLOCK #1 SINGLE	6991	6991	1
16	SCREW, PAN HEAD PHILLIPS 8-32 X 5/8	SP83258	SP83258	2
17	NUT, HEX 4-40	NH440	NH440	4
18	POWER CORD	110969174	110969175	1
19	NUT, HEX 10-32	NH1032	NH1032	1
20	WASHER, SAE 5/16	WSAE516	WSAE516	8
21	NUT, HEX 1/4-20	NH1420	NH1420	5
22	WASHER, INTERNAL TOOTH LOCK #6	WLIT6	WLIT6	4
23	MOTOR BASE	110623006	110623006	1
24	WASHER 3/8 SPLIT LOCK	WL38	WL38	4
25	WASHER, SAE 3/8	WSAE38	WSAE38	4
26	START-STOP COMBINATION BUTTON, W/EXTENDED STOP	1101097083	1101097083	1
27	GEAR MOTOR ASSEMBLY 120 VOLT US MOTOR	1101097134	1101097134	1
28	BOLT, HEX 3/8-16 X 1 STAINLESS STEEL	BH38161S	BH38161S	4
29	CONNECTOR, 1/2" MALE X 3/8" CLAMP	100455167	100455167	1
30	SCREW, PAN HEAD PHILLIPS 8-32 X 5/8	SP83258	SP83258	2
31	SCREW, PAN HEAD PHILLIPS 10-32 X 3/8	SP103238	SP103238	1

32	PULLEY, GUIDING IDLER ASSEMBLY	11059504	11059504	1
33	PAD, VIBRATION DAMPENING	1101745768001	1101745768001	1
34	TENSIONER BAR ASSEMBLY	1101097009	1101097009	1
35	PULLEY, IDLER TENSIONER ASSEMBLY	1101097123	1101097123	1
36	PULLER, IDLER ASSEMBLY	1101097124	1101097124	1
37	PULLEY, MOTOR	1101097125	1101097125	1
38	TOP ROLLER ASSEMBLY	1101097021	1101097021	2
39	DOUBLE SEALED BEARING	1101097026	1101097026	4
40	MIDDLE ROLLER SHAFT	1101097033	1101097033	1
41	MIDDLER ROLLER BRACKET ASSEMBLY	1101097034	1101097034	1
42	PULLEY, MIDDLER ROLLER	1101097126	1101097126	1
43	PLASTIC GUARD	1101097103	1101097103	2
44	MIDDLE FRONT SCRAPER #3 SPRING PIN	1101097064	1101097064	1
45	1/4-20 SERRATED HEX NUT	NHSF1420	NHSF1420	18
46	TOP CONCENTRIC BRACKET ASSY DPR2000	110100110	110100110	1
47	PIN, ROLL 3/16 X 1 1/4	PR316114	PR316114	2
48	UPPER ROLLER SHAFT	1101097027	1101097027	1
49	RIGHT SIDE CAM	1101097029	1101097029	1
50	LEFT SIDE CAM	1101097030	1101097030	1
51	PULLEY, ROLLER UPPER	1101097127	1101097127	1
52	BOLT, HEX 5/16 X 1-1/4 STAINLESS STEEL	BH51618114S	BH51618114S	4
53	WASHER, 5/16" SPLIT LOCK	WL516	WL516	4
54	SCREW, BUTTON HEAD 1/4-20 X 1/2 STAINLESS STEEL	SB142012S	SB142012S	17
55	WASHER, SAE #8	WSAE8	WSAE8	8
56	WASHER, INTERNAL TOOTH LOCK #8	WLIT8	WLIT8	7
57	SCREW, PAN HEAD PHILLIPS 8-32 X 3/4 STAINLESS STEEL	SP83234S	SP83234S	1
58	NUT, HEX 8-32	NH832	NH832	10
59	SCREW, BUTTON HEAD 5/16-18 X 1/2	SB5161812	SB5161812	3
60	TOP ROLLER GAUGE DECAL	DP110109720T	DP110109720T	1
61	SIDE COVER	11059508	11059508	1
62	SPRING, EXTENSION 12" O.D. X 3.0" LONG X 1/16" THK	SE123116	SE123116	1
63	BELT, V TYPE 1/2" WIDE X 5/16" THICK X 43" LONG	BV1251643	BV1251643	1
64	SLIDING PLATE	11059509	11059509	1
65	SAFETY COVER ASSEMBLY	11059506	11059506	1
66	SCREW, SET 1/4-20 X 3/4"	SST142034	SST142034	1

67	NUT, ACCORN 1/4-20 NICKLE PLATE	NA1420	NA1420	2
68	LOWER FRONT SCRAPER #3 SUB ASSEMBLY	11017770517	11017770517	1
69	MIDDLE FRONT SCRAPER #3 BAR	1101097063	1101097063	1
70	ANGULAR WELD STUD FOR SCRAPER #2	1101097101	1101097101	2
71	SCRAPER, TENSION SPRING	1101097052	1101097052	4
72	TOP FRONT SCRAPER #2 SUB ASSEMBLY	11017770513	11017770513	1
73	TOP FRONT SCRAPER #2 BAR	1101097057	1101097057	1
74	WASHER, INTERNAL TOOTH LOCK #10	WLIT10	WLIT10	1
75	THREADED SPACER, DPR2000	11059503	11059503	1
76	SCREW, SET 1/4-20 X 1/2	SST142012	SST142012	1
77	SCREW, BUTTON HEAD 5/16-18 X 3/4	SB5161834	SB5161834	4
78	SCREW, SET 1/4-20 X 3/8	SST142038	SST142038	2
79	FRAME WELDING ASSEMBLY DPR2000	11059501	11059501	1
80	SCREW, ROUND HEAD 4-40 X 1/2"	SR44012	SR44012	2
81	COVER, BACK	11059507	11059507	1
A1	GEAR MOTOR KIT ASSEMBLY	1105797120	1105797120	1
A2	TOP ROLLER ASSEMBLY	11059505	11059505	1
A3	MIDDLE ROLLER ASSEMBLY	1101097130	1101097130	1
A4	MIDDLE FRONT SCRAPER #3 ASSEMBLY	11017770516	11017770516	1
A5	TOP FRONT SCRAPER #2 ASSEMBLY	11017770512	11017770512	1

PROLUXE

DPR2000/DPR3000

ELECTRICAL RATING

115 VOLTS
8.8 AMPS

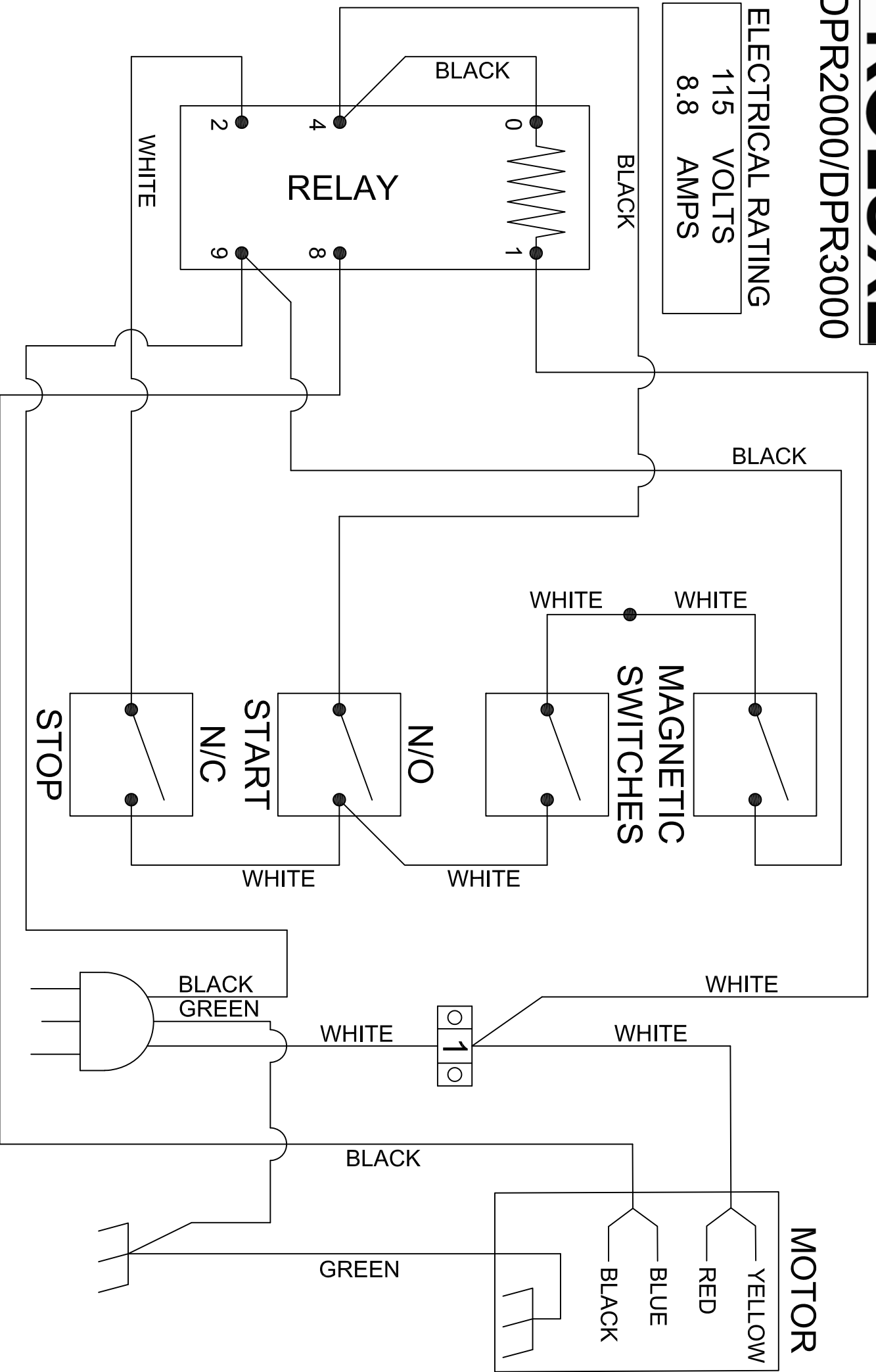

Warranty & Return Policy

Proluxe warrants all products manufactured by it against defects in workmanship or materials from the date of purchase for a period of 1 year on parts and labor. This warranty applies to only equipment purchased and used in the United States.

Warranty period shall begin when equipment ships. Warranty travel will only be covered for 60 miles.

ALL WARRANTY SERVICE CALLS MUST BE APPROVED BY PROLUXE. IF THIS PROCEDURE IS NOT FOLLOWED, WARRANTY SERVICE WILL NOT BE COVERED. WARRANTY SERVICE WILL BE PAID ON STRAIGHT TIME, OVERTIME WILL NOT BE COVERED.

Service Calls

Contact our factory to obtain warranty service. Proluxe must issue a return authorization number, and call tag, or find the name and location of a Factory Authorized Service Center nearest you. When calling for service, please furnish the model number, serial number, and a description of the problem.

EXCLUSIONS

The warranties provided by Proluxe DO NOT apply to the following:

- Damage due to misuse, abuse, alteration, or accident.
- Improper or unauthorized repairs.
- Submerged in water.
- Damaged in shipment.
- Equipment exported to foreign countries.

Special Order Equipment and Accessories

Cannot be canceled and are not returnable unless defective within the terms of this warranty.

In no event shall Proluxe be liable for consequential damages arising out of the failure of any of its products if operated improperly or caused by normal wear or damaged by operator abuse.

Limited Lifetime Warranty on Heating Elements

If replacement is needed, Proluxe will send the new part at no charge but labor will not be covered unless the unit is still under the 1 year manufacturer warranty.

RETURNED MERCHANDISE POLICY

Should it become necessary to return any of the company's products, the following instructions must be adhered to: First, contact our customer service department for approval and a return authorization number.

Please have the serial number of your item available at that time. All merchandise must be shipped freight prepaid by customer or service agency. Subject to the inspection of the product by the company, a restocking charge of 20% of the Net purchased price paid to Proluxe will be assessed. Merchandise may not be returned for credit without prior written approval of Proluxe.

Collect shipments will not be accepted. No returns after 60 days of original shipment date on machines. Purchased parts may not be returned after 30 days. If upon inspection by Proluxe or its authorized agent it is determined the equipment has not been used in an appropriate manner, has been modified, or has not been properly maintained, or has been subject to misuse, misapplication, neglect, abuse, accident, unauthorized modification, damage during transit, delivery, fire, flood, act or war, riot or act of God, then this warranty shall be deemed null and void.

TERMS & CONDITIONS

1. Price List prices are suggested retail prices and are shown in U.S. Dollars.

2. Terms of Payment: 1% 10 days, NET 30 days.

3. New Accounts: Satisfactory credit information must be provided before open account status can be extended.

Unless agreed otherwise, all shipments will be made C.O.D., Cash in advance.

4. Pricing: Prices, specifications, model numbers, capacities and accessories are subject to change without notice.

5. Freight/Routing: Method of shipment will be determined by Proluxe unless otherwise advised by purchaser.

6. Damaged Claims: All merchandise shipped at purchaser's risk. Inspection must be made by purchaser at time goods are received. If goods are damaged, the PURCHASER shall request that the agent of the transportation company make a written notation on the proper shipping documents immediately and then file a claim for damages.

Note: Goods damaged in shipping are non-returnable.

7. Returns: Machines may not be returned after 60 days. Purchased parts may not be returned after 30 days. A restocking fee of 20% will be assessed on non-warranty returns.

8. Taxes: Prices indicated herein DO NOT include State, Federal, Local or foreign taxes or duties, nor do they include fees, permits, insurance or other levies, all of which are the responsibility of the purchaser.

9. All orders are subject to acceptance by Proluxe.

10. Possession of this price list shall not be considered an offer to sell